



SPEED QUEEN® MULTI-HOUSING LAUNDRY SOLUTIONS

Top Load Washer Peak Performance

Quantum® Gold Pro

Prep for Card | Coin Drop Installed | Prep for Coin

Built for Reliable Performance

Speed Queen's two-speed top load washer, defined by its simplicity and its performance, provides everything you need to get the job done – and nothing you don't. Speed Queen's top load washer combines heavy-duty construction with reliable operation proven to stand the test of time. Speed Queen® washers provide maximum energy efficiency and long-lasting performance.

- Touch pad control with sound annunciator
- 27 cycle selections

- Extract speed of 710 RPM spins clothes out drier
- Integrated meter case
- Advanced suspension system
- Easy-to-read digital display
- Cycle programming flexibility
- Multi-level vend pricing
- Individual cycle modifier keys
- Durable stainless steel tub standard
- 2.83 cu. ft. (80.14 liters) wash capacity
- Large capacity meter case standard
- Wash Alert™ capability



Quantum® Gold Pro Control

The Quantum® Gold Pro control delivers a truly premium experience to residents. From intuitive soft touch buttons that walk them through cycle options to multiple actuations (coin, card, mobile) for payment flexibility, this control gives residents the wash and dry options they want, and the revenue potential managers desire.



Top Load Washer Peak Performance

Quantum® Gold Pro

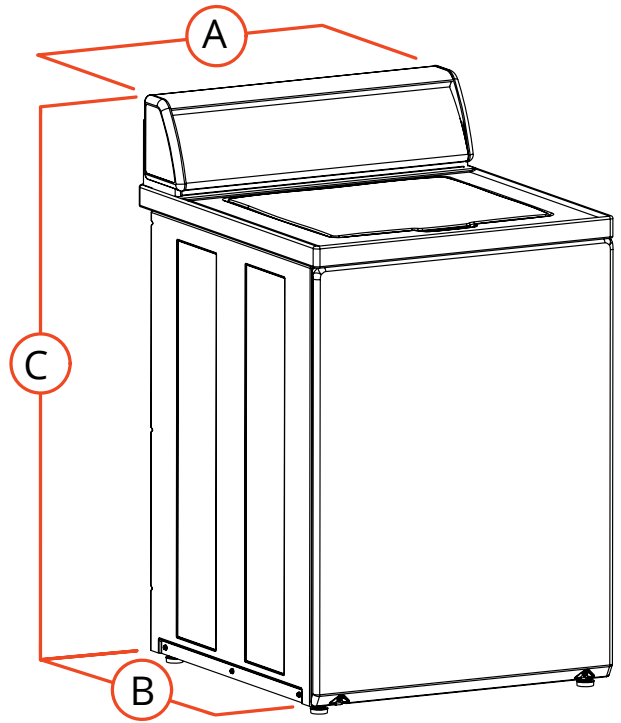
Specifications		
Control Option	Quantum Gold Pro	
Color	White	
Capacity - lb (kg)	14 (6.4)	
Overall Width - in (mm)	25.63 (651)	
Overall Depth - in (mm)	28 (711)	
Overall Height - in (mm)	43 (1092)	
Cylinder Volume - cu. ft. (liters)	2.83 (80.14)	
Spin Speed G-Force (RPM)	150 (710)	
Motor Size - HP (kw)	0.5 (0.37)	
Water Consumption Per Cycle - g (liter)**	24.9 (94.3)	
IWF (Water Factor) - gal/ft ³ (liters/liter/cycle)**	8.8 (1.18)	
MEF ₂ (Modified Energy Factor) ft ³ /kWh/cycle (Liters/kWh/cycle)**	1.35 (38.2)	
Available Water Temperatures	Cold, Warm, Hot	
Available Cycles	Normal, Synthetic, Delicate	
Electrical Requirements (v/Hz/Ph-Amp)	120/60/1 - 15 Amp	
Water Pressure - p.s.i. (bar)	20-120 (1.4/8.3)	
Drain	Pump	
Cylinder Finish	Stainless Steel	
Net Weight - lb (kg)	206 (93.4)	
Shipping Weight - lb (kg)	218 (98.8)	
Shipping Dimensions Approx. - in (mm)	Width	28 (711)
	Depth	30 (762)
	Height	45 (1143)
Agency Approvals	cULus	



A. Overall Width - in (mm)	25.625 (651)
B. Overall Depth - in (mm)	28 (711)
C. Overall Height - in (mm)	43 (1092)

Models	Actuation
SWNNC2HP116TW01	Coin Drop Installed 
SWNNX2HP116TW01	Prep for Coin 
SWNNY2HP116TW01	Prep for Card 

** Average usage based on multiple load sizes and current DOE test protocol. Real usage will vary depending on load size, composition and cycle selectivity.

For the most accurate information, the installation guide should be used for all design and construction purposes. Due to continuous product improvements, design and specifications subject to change without notice. The quality management systems of Alliance Laundry Systems are registered to ISO 9001.